

# 1/4" Hex. Super Duty Air Screwdriver

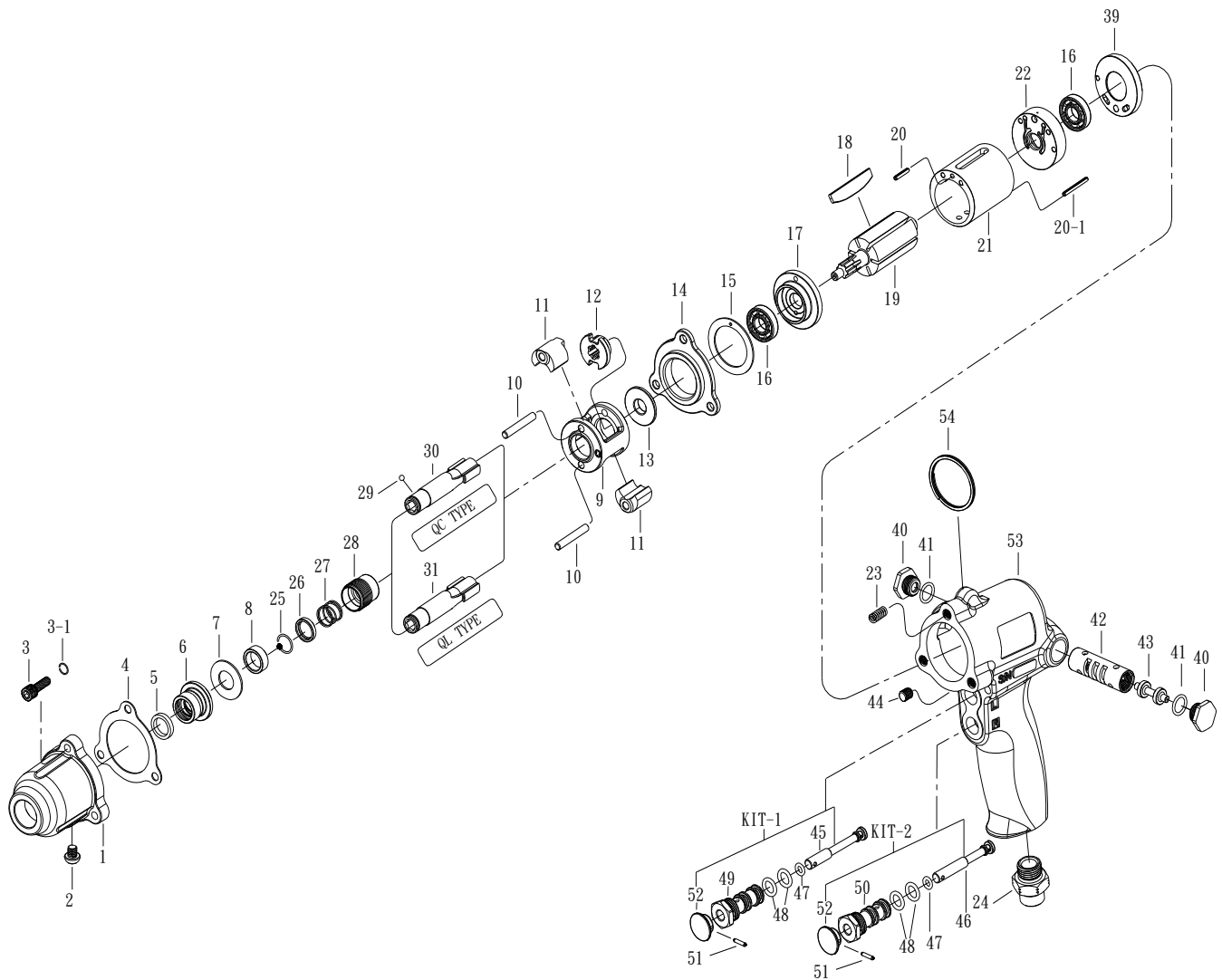

## 3266P-QC/3266P-QL

INDEX NO.	DESCRIPTION	REQ'D NO.	INDEX NO.	DESCRIPTION	REQ'D NO.
1	Hammer Case	1	25	Socket Retainer	1
2	Screw	1	26	Washer	1
3	Screw	3	27	Spring	1
3-1	Spring Washer	3	28	Release Sleeve	1
4	Gasket	1	29	Steel Ball	1
5	Felt Ring	1	30	Anvil (for KI-3266-QC)	1
6	Bushing	1	31	Anvil (for KI-3266-QL)	1
7	Washer	1	39	Gasket	1
8	Axle Bushing	1	40	Screw	2
9	Hammer Frame	1	41	O-Ring	2
10	Hammer Pin	2	● 42	Reverse Valve Bushing	1
11	Hammer	2	● 43	Reverse Valve	1
12	Hammer Cam	1	● 44	Set Screw	2
13	Spacer	1	● 45	Throttle Valve Plunger	1
14	Hammer Case Pivot	1	● 46	Throttle Valve Plunger	1
15	Gasket	1	● 47	O-Ring	2
16	Ball Bearing	2	● 48	O-Ring	4
17	Front End Plate	1	● 49	Valve Bushing	1
18	Rotor Blade	6	● 50	Valve Bushing	1
19	Rotor	1	● 51	Spring pin	2
20	Spring pin	1	● 52	Trigger	2
20-1	Spring pin	1	★ 53	Motor Housing Assembly {incl.23 ( 3 ).42.44 ( 2 ).}	1
21	Cylinder	1	54	Hanger	1
22	Rear End Plate	1	★ KIT-1	Trigger Assembly {incl.45.47.48 ( 2 ).49.51.52}	1
● 23	Heli-Coil	3	★ KIT-2	Trigger Assembly {incl.46.47.48 ( 2 ).50.51.52}	1
24	Air Inlet	1	TK	Tune-Up Kit { 15.16(2).18(6).41(2)47(2).48(4) }	

- ★ Must be Purchased in Assembly Set
- Recommended not to be purchased alone due to assem

PA6-03266P-5

20110426R2